



OPERATOR'S MANUAL

A Division of Snow Joe®, LLC

CORDLESS CHAIN SAW SHARPENER

24-VOLT MAX* | 2.0 Ah

Model 24V-CSSHRP-LTE

Form No. SJ-24V-CSSHRP-LTE-880E-M

IMPORTANT! Safety Instructions

All Operators Must Read These Instructions Before Use

Read all instructions before using this cordless chain saw sharpener. Basic safety precautions should always be followed to reduce the risk of fire, electric shock and personal injury.

General Safety WARNINGS!

You and any other operator of this chain saw sharpener must read, understand and follow these instructions in their entirety. Failure to follow these instructions may result in ELECTRIC SHOCK, FIRE and/or serious PERSONAL INJURY.

Notice the personal safety alert symbol  used in this manual to draw your attention to a WARNING given along with the particular operating instruction. This means that the operation requires special ATTENTION, CAUTION and AWARENESS.

The warnings, cautions, and instructions in this manual cannot cover all possible conditions or situations that could occur. Exercise common sense and caution when using this tool. Always be aware of the environment and ensure that the tool is used in a safe and responsible manner.

 WARNING! This machine can be dangerous! Careless or improper use can cause serious injury.

 WARNING! The rotating grinding wheel can cut you. Keep hands and feet away from the wheel and the cutting area.

- Before using the chain saw sharpener, familiarize yourself with the controls, especially how to stop the chain saw sharpener in an emergency. The only individuals who should use the chain saw sharpener are those who thoroughly understand these instructions and know how to properly operate the machine. Children should never be allowed access to the chain saw sharpener.
- Do not allow persons to operate or assemble the product until they have read this manual and have developed a thorough understanding of how it works.
- Do not modify this product in any way. Unauthorized modification may impair the function and/or safety and could affect the life of the product. There are specific applications for which the product was designed.

- Use the right tool for the job. DO NOT attempt to force small equipment to do the work of larger industrial equipment. There are certain applications for which this equipment was designed. This product will be safer and do a better job at the capacity for which it was intended. DO NOT use this equipment for a purpose for which it was not intended.

Work Area Safety

1. **Keep work area clean and well lit** – Cluttered, dark areas invite accidents.
2. **Avoid dangerous environments** – Do not use the chain saw sharpener in rain or in damp or wet locations. Do not operate the chain saw sharpener in gaseous or explosive atmospheres or use the chain saw sharpener near flammable or combustible liquids. Motors in these tools normally spark, and the sparks might ignite fumes.
3. Do not allow the product to come into contact with an electrical source. The tool is not insulated and contact will cause electrical shock.
4. **Keep children, bystanders and pets away** – All spectators, including pets, should be kept a safe distance away from the work area.
5. **Make workshop kid proof** with padlocks, master switches, or by removing starter keys.

Personal Safety

1. **Stay alert** – Watch what you are doing. Use common sense. Do not operate the cordless chain saw sharpener when you are tired or under the influence of alcohol or drugs. A moment of inattention while operating the tool may result in serious personal injury.
2. **Dress properly** – Do not wear loose articles of clothing or jewelry. They can come into contact and get caught in the grinding wheel or any other moving part. Non-slipping footwear is recommended. Wear protective hair covering to contain long hair.
3. **Do not overreach** – Keep proper footing and balance at all times.
4. **Never operate the machine on an unstable platform** – Always work in a safe and stable position. Serious injury could occur if the machine is tipped or the grinding wheel is unintentionally contacted.
5. **Remove adjusting keys and wrenches** – Always make sure the adjusting keys and wrenches are removed before turning on the machine.

6. **Secure work** – Use the chain guide lock to secure the chain to free both hands for moving the motor head/ grinding wheel.

Chain Saw Sharpener Use and Care

1. **Do not force the tool** – It will perform better with less likelihood of personal or mechanical injury if it is used at the rate for which it was designed.
2. **Use the right product** – Do not use this machine for any job except that for which it is intended.
3. **Check for damaged parts** – Carefully check that the product will operate properly and perform its intended function. Replace damaged or worn parts immediately. Never operate the product with a damaged part.
4. **Safety switch** – Do not use a product with a malfunctioning switch. Any power tool that cannot be controlled with the power switch is dangerous and must be repaired by an authorized service representative before using.
5. **Disconnect the tool** – Turn off the power switch and remove the battery when it is not in use, before servicing it, when changing accessories and when performing any other maintenance task.
6. **Store idle tool indoors** – When not in use, the cordless chain saw sharpener should be stored indoors in a dry, locked place out of the reach of children. Inspect the tool prior to storage and before re-use.
7. **Replacement parts** – When servicing this unit, use only identical replacement parts. Replace or repair damaged cord immediately on the charger.
8. **Use recommended accessories** – Consult page 17 for recommended accessories. The use of improper accessories could cause personal injury or property damage. To guarantee the efficiency and consistent performance of the machine, replace any worn or broken parts with only genuine parts from Snow Joe® + Sun Joe®.
9. **Moving parts** – Keep hands and feet away from moving parts.
10. **Keep guard in place and in good working order** – Never start the machine without the grinding wheel guard in place.
11. **Maintain the cordless chain saw sharpener with care** – Follow the applicable maintenance instructions for replacing parts and changing accessories. Lubrication is not required.
12. **Do not stand on the machine** – Serious injury could occur if the tool is tipped or if the cutting edge is unintentionally contacted.
13. **Never leave tool running unattended** – Turn off and remove the battery. Don't leave tool until it comes to a complete stop.

Service

 **WARNING!** Have your power tool serviced by a qualified repair person using only identical replacement parts. This will ensure that the safety of the power tool is maintained.

1. Replace cracked wheel immediately.
2. Always use guards and eye shields.
3. Do not overtighten the grinding wheel retainer.
4. Use only retainers furnished with the chain saw sharpener.
5. Frequently clean grinding dust that accumulate under the chain saw sharpener.

 **WARNING!** Risk of injury due to accidental starting. Do not use in an area where children may be present.

Specific Safety Rules for Chain Saw Sharpener and the Grinding Wheel

- Use only identical replacement grinding wheel.
- Keep hands clear from grinding wheel during use. Never try to stop the grinding wheel by your hands.
- Electric shock hazard. Do not expose to rain or use in damp locations.
- Do not use for wet grinding.
- Not for use by or around children.
- Always keep the hand grips clean and dry.
- Switch off the machine and disconnect battery pack from tool before making any adjustments, changing accessories, or storing the tool. Such preventive safety measures reduce the risk of starting the tool accidentally.
- Do not push the On/Off switch any more if the protective circuit is triggered. This may damage the battery.
- Always wear the proper personal protective equipment including heavy-duty gloves when handling the wheel.
- Do not use a wheel that is cracked or chipped.
- Before starting the machine, make sure the grinding wheel is correctly secured and positioned up in rest mode. Do not overtighten the wheel mounting retainer.
- Always ensure the appropriate wheel guards are installed.
- Store out of reach of children.

Battery + Charger

Safety Instructions

We pay a great deal of attention to the design of every battery pack to ensure that we supply you with batteries that are safe, durable and have a high energy density. The battery cells have a wide range of safety devices. Each individual cell is initially formatted and its electrical characteristic curves are recorded. This data is then used exclusively to be able to assemble the best possible battery packs.

Despite all the safety precautions, caution must always be exercised when handling batteries. The following points must be obeyed at all times to ensure safe use. Safe use can only be guaranteed if undamaged cells are used. Incorrect handling of the battery pack can cause cell damage.

IMPORTANT! Analyses confirm that incorrect use and poor care of high-performance batteries are the main factors responsible for personal and/or product damage.

 **WARNING!** Use only approved replacement batteries; other batteries may damage the cordless chain saw sharpener and cause it to malfunction, which can lead to serious personal injury.

 **WARNING!** Do not use a battery pack or appliance that is damaged or modified. Damaged or modified batteries may exhibit unpredictable behavior resulting in fire, explosion or risk of injury.

Do not modify or attempt to repair the appliance or the battery pack except as indicated in the instructions for use and care.

Have your battery pack serviced by a qualified repair person using only identical replacement parts. This will ensure that the safety of the battery pack is maintained.

 **CAUTION!** To reduce the risk of injury, charge the 24V iON+ lithium-ion battery pack only in its designated 24V iON+ lithium-ion charger. Other types of chargers present risk of fire, personal injury and damage. Do not wire a battery pack to a power supply plug or car cigarette lighter. Such misuse will permanently disable or damage the battery pack.

- **Avoid dangerous environments** – Do not charge the battery pack in rain, snow or in damp or wet locations. Do not use the battery pack or charger in the presence of explosive atmospheres (gaseous fumes, dust or flammable materials) because sparks may be generated when inserting or removing the battery pack, which could lead to a fire.
- **Charge in a well-ventilated area** – Do not block the charger vents. Keep them clear to allow for proper ventilation. Do not allow smoking or open flames near a charging battery pack. Vented gases may explode.

NOTE: The safe temperature range for the battery is 41°F – 105°F (5°C – 40.5°C). Do not charge the battery outside in freezing weather; charge it at room temperature.

- **Maintain charger cord** – When unplugging the charger, pull the plug, not the cord, from the receptacle to reduce the risk of damage to the electrical plug and cord. Never carry the charger by its cord or yank it by the cord to disconnect it from the receptacle. Keep the cord away from heat, oil and sharp edges. Make sure the cord will not be stepped on, tripped over or subjected to damage or stress when the charger is in use. Do not use the charger with a damaged cord or plug. Replace a damaged charger immediately.
- **Do not use an extension cord unless it is absolutely necessary** – Using the wrong, damaged or improperly wired extension cord poses a risk of fire and electric shock. If an extension cord must be used, plug the charger into a properly wired 16 gauge or larger extension cord with the female plug matching the male plug on the charger. Make sure that the extension cord is in good electrical condition.
- **Charger 24VCHRG-AC is rated for 100 - 240 volt AC only** – The charger must be plugged into an appropriate receptacle.
- **Use only recommended attachments** – Use of an attachment not recommended or sold by the battery charger or battery pack manufacturer may result in risk of fire, electric shock or personal injury.
- **Unplug charger when not in use** – Make sure to remove battery packs from unplugged chargers.

 **WARNING!** To reduce the risk of electric shock, always unplug the charger before performing any cleaning or maintenance. Do not allow water to flow into the charger. Use a Ground Fault Circuit Interrupter (GFCI) to reduce shock hazards.

- **Do not burn or incinerate battery packs** – Battery packs may explode, causing personal injury or damage. Toxic fumes and materials are created when battery packs are burned.
- **Do not crush, drop or damage battery packs** – Do not use the battery pack or charger if they have sustained a sharp blow, been dropped, run over or have been damaged in any way (i.e. pierced with a nail, hit with a hammer, stepped on, etc.).
- **Do not disassemble** – Incorrect reassembly may pose a serious risk of electric shock, fire or exposure to toxic battery chemicals. If the battery or charger are damaged, contact an authorized Snow Joe® + Sun Joe® dealer or call the Snow Joe® + Sun Joe® customer service center at 1-866-SNOWJOE (1-866-766-9563) for assistance.
- **Battery chemicals cause serious burns** – Never let a damaged battery pack contact the skin, eyes or mouth. If a damaged battery pack leaks battery chemicals, use rubber or neoprene gloves to safely dispose of it. If skin is exposed to battery fluids, wash the affected area with soap and water and rinse with vinegar. If eyes are exposed to battery chemicals, immediately flush with water for 20 minutes and seek medical attention. Remove and dispose of contaminated clothing.
- **Do not short circuit** – A battery pack will short circuit if a metal object makes a connection between the positive

and negative contacts on the battery pack. Do not place a battery pack near anything that may cause a short circuit, such as paper clips, coins, keys, screws, nails and other metallic objects. A short-circuited battery pack poses a risk of fire and severe personal injury.

- **Store your battery pack and charger in a cool, dry place** – Do not store the battery pack or charger where temperatures may exceed 105°F (40.5°C), such as in direct sunlight or inside a vehicle or metal building during the summer.

Information about the battery

1. The battery pack supplied with your cordless chain saw sharpener is only partially charged. The battery pack has to be charged completely before you use the tool for the first time.
2. For optimum battery performance, avoid low discharge cycles by charging the battery pack frequently.
3. Store the battery pack in a cool place, ideally at 77°F (25°C) and charged to at least 40%.
4. Lithium-ion batteries are subject to a natural aging process. The battery pack must be replaced at the latest when its capacity falls to just 80% of its capacity when new. Weakened cells in an aged battery pack are no longer capable of meeting the high power requirements needed for the proper operation of your chain saw sharpener, and therefore pose a safety risk.
5. Do not throw battery packs into an open fire as this poses a risk of explosion.
6. Do not ignite the battery pack or expose it to fire.
7. Do not exhaustively discharge batteries. Exhaustive discharge will damage the battery cells. The most common cause of exhaustive discharge is lengthy storage or non-use of partially discharged batteries. Stop working as soon as the performance of the battery falls noticeably or the electronic protection system triggers. Place the battery pack in storage only after it has been fully charged.
8. Protect batteries and the tool from overloads. Overloads will quickly result in overheating and cell damage inside the battery housing even if this overheating is not apparent externally.
9. Avoid damage and shocks. Immediately replace batteries that have been dropped from a height of more than one meter or those that have been exposed to violent shocks, even if the housing of the battery pack appears to be undamaged. The battery cells inside the battery may have suffered serious damage. In such instances, please read the waste disposal information for proper battery disposal.
10. If the battery pack suffers overloading and overheating, the integrated protective cutoff will switch off the equipment for safety reasons.

IMPORTANT! Do not press the ON/OFF switch any more if the protective cut-off has been activated. This may damage the battery pack.

11. Use only original battery packs. The use of other batteries poses a fire risk and may result in injuries or an explosion.

Information about the charger and the charging process









1. Please check the data marked on the rating plate of the battery charger. Be sure to connect the battery charger to a power supply with the voltage marked on the rating plate. Never connect it to a different mains voltage.
2. Protect the battery charger and its cord from damage. Keep the charger and its cord away from heat, oil and sharp edges. Have damaged cords repaired without delay by a qualified technician at an authorized Snow Joe® + Sun Joe® dealer or call the Snow Joe® + Sun Joe® customer service center at 1-866-SNOWJOE (1-866-766-9563).
3. Electrical plugs must match the outlet. Never modify the plug in any way. Do not use any adapter plugs with grounded appliances. Unmodified plugs and matching outlets will reduce the risk of electric shock.
4. Keep the battery charger, battery pack and the cordless tool out of the reach of children.
5. Do not use the supplied battery charger to charge other cordless tools.
6. During periods of heavy use, the battery pack will become warm. Allow the battery pack to cool to room temperature before inserting it into the charger to recharge.
7. Do not overcharge batteries. Do not exceed the maximum charging times. These charging times only apply to discharged batteries. Frequent insertion of a charged or partially charged battery pack will result in overcharging and cell damage. Do not leave batteries in the charger for days on end.
8. Never use or charge batteries if you suspect that it has been more than 12 months since the last time they were charged. There is a high probability that the battery pack has already suffered dangerous damage (exhaustive discharge).
9. Charging batteries at a temperature below 41°F (5°C) will cause chemical damage to the cells and may cause a fire.
10. Do not use batteries that have been exposed to heat during the charging process, as the battery cells may have suffered dangerous damage.
11. Do not use batteries that have suffered curvature or deformation during the charging process or those that exhibit other atypical symptoms (gassing, hissing, cracking, etc.).
12. Never fully discharge the battery pack (maximum recommended depth of discharge is 80%). A complete discharge of the battery pack will lead to premature aging of the battery cells.

Protection from environmental influences

1. Wear suitable work clothes. Wear safety goggles.
2. Protect your cordless tool and the battery charger from moisture and rain. Moisture and rain can cause dangerous cell damage.
3. Do not use the cordless tool or the battery charger near vapors and flammable liquids.
4. Use the battery charger and cordless tools only in dry conditions and at an ambient temperature of 41°F – 105°F (5°C – 40.5°C).
5. Do not keep the battery charger in places where the temperature is liable to reach over 105°F (40.5°C). In particular, do not leave the battery charger in a car that is parked in the sunshine.
6. Protect batteries from overheating. Overloads, overcharging and exposure to direct sunlight will result in overheating and cell damage. Never charge or work with batteries that have been overheated – replace them immediately, if possible.
7. Store the charger and your cordless tool only in dry locations with an ambient temperature of 41°F – 105°F (5°C – 40.5°C). Store your lithium-ion battery pack in a cool, dry place at a temperature of 77°F (25°C). Protect the battery pack, charger and cordless tool from humidity and direct sunlight. Only place fully charged batteries in storage (charged to at least 40%).
8. Prevent the lithium-ion battery pack from freezing. Battery packs that were stored below 32°F (0°C) for more than 60 minutes must be discarded.
9. When handling batteries, be wary of electrostatic charge. Electrostatic discharges can damage the electronic protection system and the battery cells. Avoid electrostatic charging and never touch the battery poles.

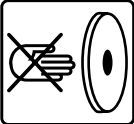
Safety Symbols

The following table depicts and describes safety symbols that may appear on this product. Read, understand and follow all instructions on the machine before attempting to assemble and operate.

Symbols	Descriptions	Symbols	Descriptions
	READ THE OPERATOR'S MANUAL(S) – Read, understand and follow all instructions in the user manual(s) before attempting to assemble and operate.		WARNING! Do not expose the unit to rain or wet conditions. Keep dry.
	SAFETY ALERT – Indicates a precaution, a warning or a danger.		Wear hearing protection. Wear eye protection. Wear breathing protection.
	Wear safety footwear at all times to provide protection against objects that may accidentally fall on feet.		Risk of injury due to rotating tool! Keep hands away.
	Do not use defective grinding discs.		The rotating part will continuously run for several seconds after you turn off the machine.
	Indoor use only. Only use battery charger indoors.		

Know Your Chain Saw Sharpener

Read the owner's manual and safety rules carefully before operating your cordless chain saw sharpener. Compare the illustration below to the actual unit in order to familiarize yourself with the location of the various controls and adjustments. Save this manual for future reference.

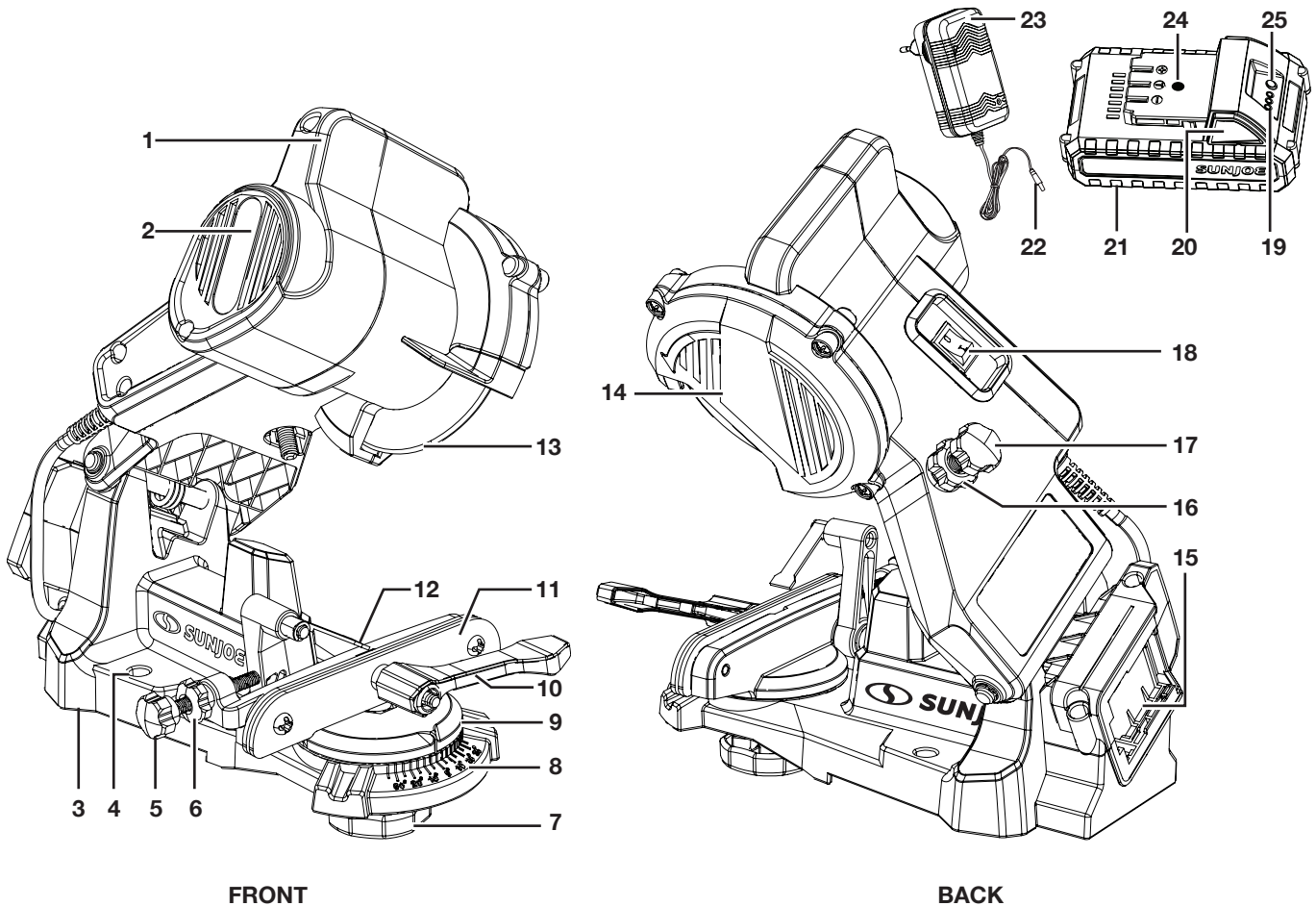

- 1. Upper handle
- 2. Motor head assembly
- 3. Mounting base
- 4. Mounting hole (2)
- 5. Chain stop adjusting knob
- 6. Chain stop locking knob
- 7. Swivel angle adjusting knob
- 8. Grinding table scale
- 9. Grinding table
- 10. Chain guide lock
- 11. Chain guide
- 12. Chain stop
- 13. Grinding wheel

- 14. Grinding wheel guard
- 15. Battery compartment
- 16. Grinding depth locking knob
- 17. Grinding depth adjusting knob
- 18. On/Off switch
- 19. Battery indicators
- 20. Push lock button (2)
- 21. 24V iON+ lithium-ion battery (24VBAT-LTE) featuring exclusive EcoSharp® technology
- 22. Charger plug
- 23. 24V iON+ lithium-ion charger (24VCHRG-AC)
- 24. Charge socket
- 25. Push button for battery indicator

Technical Data

Battery Voltage*	24V D.C.
Battery Capacity	2.0 Ah
Battery Charge Time Max.	1 hr 20 mins
Battery Run Time Max.	40 mins
Charger Input	100 – 240 V AC, 50 – 60 Hz, 50 W
Charger Output	25.2 V DC,  1400 mA
Motor	65.5 W
Grinding Speed Max	6500 rpm
Angle Adjustment Max	30 degrees left or right
Arbor	7/8 in. (22 mm)
Grinding Wheel Diameter	4.25 in. (108 mm)
Grinding Wheel Thickness	1/8 in. (3.2 mm)
Grinding Wheel Grit	100
Grinding Wheel Material	Aluminum Oxide
Chain Gauge	0.05 in. – 0.07 in. (1.3 mm – 1.8 mm)
Chain Pitch	1/4 in. + 3/8 in. + 0.325 in. (6.35 mm + 9.5 mm + 8.3 mm)
Weight	3.74 lbs (1.7 kg) (chain saw sharpener alone)
Weight	4.7 lbs (2.1 kg) (chain saw sharpener with battery installed)

*Initial no-load voltage, when fully charged, peaks at 24 volts; nominal voltage under typical load is 21.6 volts.

Unpacking

Carton Contents

- Cordless chain saw sharpener
- 24V iON+ lithium-ion battery
- 24V iON+ lithium-ion battery charger
- Manuals with registration card

1. Carefully remove the cordless chain saw sharpener and check to see that all of the above items are supplied.
2. Inspect the product carefully to make sure no breakage or damage occurred during shipping. If you find damaged or missing parts, DO NOT return the unit to the store. Please call the Snow Joe® + Sun Joe® customer service center at 1-866-SNOWJOE (1-866-766-9563).

NOTE: Do not discard the shipping carton and packaging material until you are ready to use your new cordless chain saw sharpener. The packaging is made of recyclable materials. Properly dispose of these materials in accordance with local regulations.

IMPORTANT! The equipment and packaging material are not toys. Do not let children play with plastic bags, foils or small parts. These items can be swallowed and pose a suffocation risk!

Assembly

⚠ CAUTION! Do not install the battery before fully assembling the unit.

⚠ WARNING! Mount the components very carefully so as not to impair the safety and efficiency of the machine. If in doubt, please call the Snow Joe® + Sun Joe® customer service center at 1-866-SNOWJOE (1-866-766-9563).

The equipment comes fully assembled. Fasten it securely to a suitable surface (e.g., a work-bench) in a suitable place (protected against dust, dry, well-lit) and it's ready for using.

1. Position the machine at a suitable surface. Push it onto the surface as far as possible until the mounting stop on the bottom prevent the machine from going any further (Fig. 1).

NOTE: It's recommended to mount the machine at chest height for best visibility and easy operation.

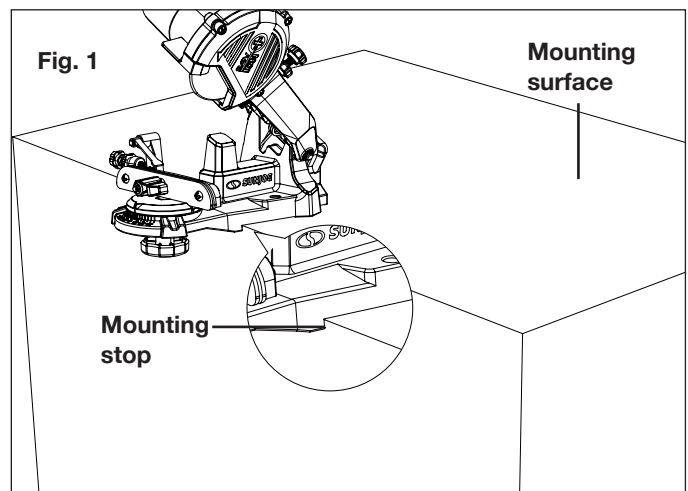

2. Insert two M8 bolts into the mounting holes on both sides (Fig. 2). Tighten to secure the machine on the mounting surface.

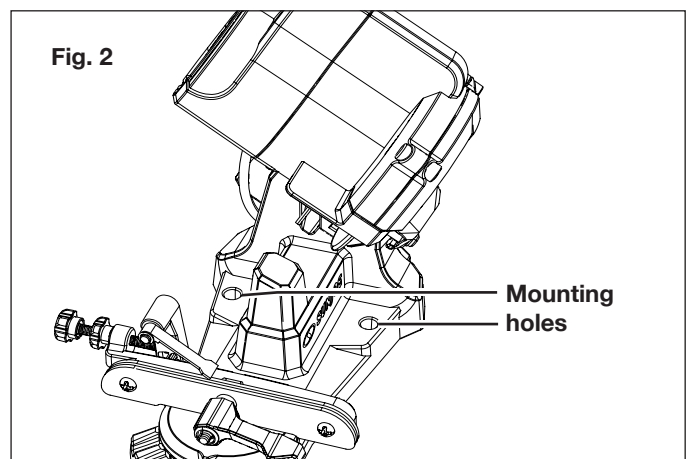

Battery Pack Operation





The equipment is powered by a lithium-ion battery. The battery pack is completely sealed and maintenance free.

⚠️ WARNING! Before first use, the battery requires at least 1 hr 20 mins charge time to be fully charged. When the battery is at low capacity, recharge for 1 hr 20 mins again before resuming operation.

Battery Charge Level Indicator

The battery pack is equipped with a push button for checking the charge level. Simply press the push button to read off the battery charge level from the LEDs of the battery indicator:

- All 3 level monitoring LEDs are lit: Battery charge level is high.
- 2 level monitoring LEDs are lit: Battery charge level is decreasing. Stop work as soon as possible.
- 1 level monitoring LED is lit: Battery is flat. Stop work IMMEDIATELY and charge the battery. Otherwise the battery's service life will be greatly shortened.

Lights	Light Indicators
	Charge level button
	The battery is at 30% capacity and requires charging
	The battery is at 60% capacity and requires charging soon
	The battery is at full capacity

NOTE: If the charge level button does not appear to be working, connect the battery to the charger and charge as needed.

NOTE: Immediately after using the battery pack, the charge level button may display a lower charge than it will if checked a few minutes later. The battery cells "recover" some of their charge after resting.

Charger Operation

⚠️ WARNING! Charge only Snow Joe® 24V lithium-ion battery pack with its compatible Snow Joe® 24V lithium-ion charger. Other types of batteries may cause personal injury and damage.

To reduce the risk of electric shock, do not allow water to flow into the charger's AC/DC plug.

When to Charge the iON+ 24VBAT-LTE Lithium-Ion Battery

NOTE: The iON+ 24VBAT-LTE lithium-ion battery packs do not develop a "memory" when charged after only a partial discharge. Therefore, it is not necessary to run down the battery pack before connecting it with the charger.

- Use the battery charge indicator lights to determine when to charge your iON+ 24VBAT-LTE lithium-ion battery pack.
- You can "top-off" your battery pack's charge before starting a big job or after a long day of use.

Charging the Battery

1. Press the push lock buttons on the battery to pull the battery pack out of the equipment (Fig. 3).

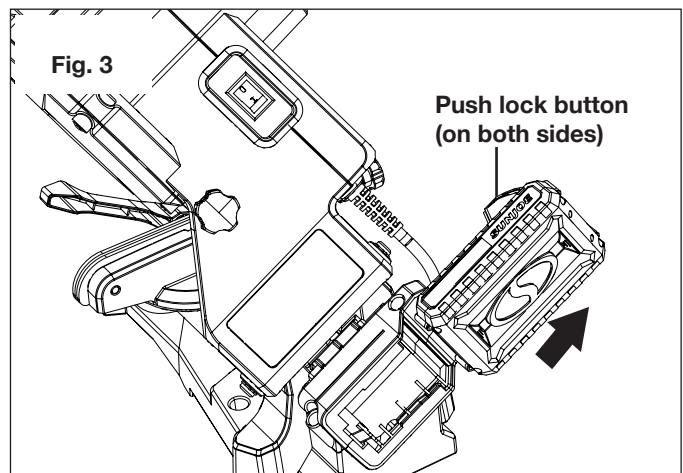

2. Check that the mains voltage is the same as that marked on the rating plate of the battery charger. Then, plug the charger adapter into an appropriate AC power outlet. Connect the charger plug into the charge socket of the battery to start charging (Fig. 4).

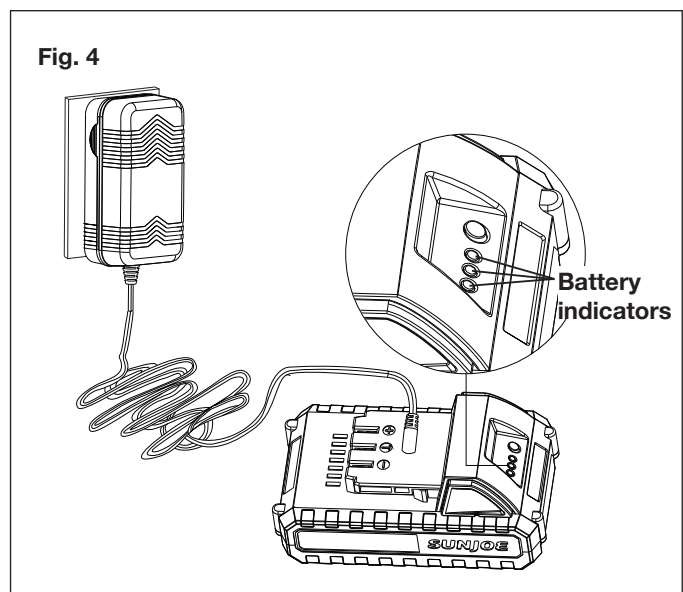

- The battery will take approximately 1 hr 20 mins to charge. The battery indicator LEDs will twinkle and illuminate one by one during the charging process. Unplug the charger immediately when the 3 LEDs are all illuminated.

⚠ CAUTION! FIRE HAZARD. When disconnecting the charger from the battery, be sure to unplug the charger from the outlet first, then disconnect the charger from the battery.

⚠ WARNING! This charger does not automatically turn off when the battery is fully charged. Please take care not to leave the battery plugged into the charger. Switch off or unplug the charger at the mains when charging is complete.

- Timely recharging of the battery will help prolong the battery's life. You must recharge the battery pack when you notice a drop in the equipment's power.

IMPORTANT! Never allow the battery pack to become fully discharged as this will cause irreversible damage to the battery.

Operation

This cordless chain saw sharpener is used to sharpen the individual teeth on a saw chain blade. The unique adjustments of the machine allow you to set the proper depth and angle for accurately sharpening the teeth. By following a basic setup procedure you can accurately use this chain saw sharpener.

Before sharpening the saw chain, gather the correct specifications for the saw chain you are going to sharpen on this cordless chain saw sharpener. These specifications can be found on the box or package that the saw chain came in when you first purchased it.

⚠ WARNING! There is a risk of serious personal injury for the operators and the bystanders from improper sharpened saw chain. Read and follow all manufacturer's instructions for your saw chain.

⚠ WARNING! All adjustments must be made prior to inserting the battery.

Position the Saw Chain

- Clean the chain before sharpening it. Wash it with a non-flammable solvent. Don't use gasoline to dry the chain.
- Lift up the chain stop and position the chain in the chain guide. Lower the chain stop so that it is positioned on the tooth you want to start with. (Fig. 5).

NOTE: It's recommended to mark the first chain tooth you start with.

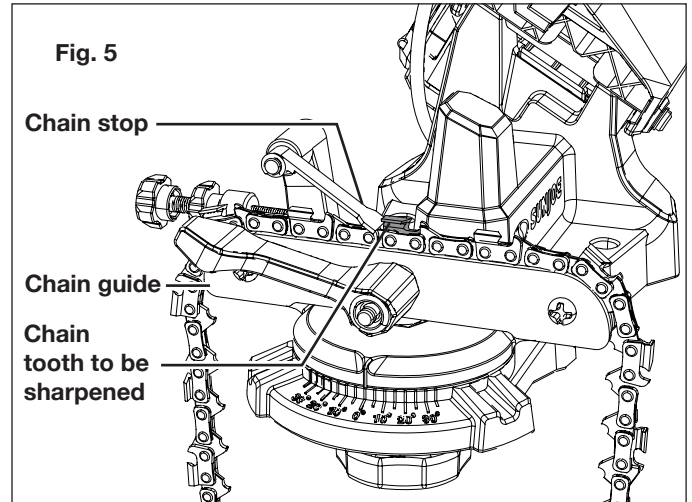

Set the Swivel Angle

Different chains have different swivel angles for sharpening. The specific information should be obtained from the manufacturer of the chain.

The adjusting knob of the swivel angle is on the bottom of the machine and allows the grinding table to swivel generally from -30 to 30 degrees. To adjust the swivel angle, follow the instruction below.

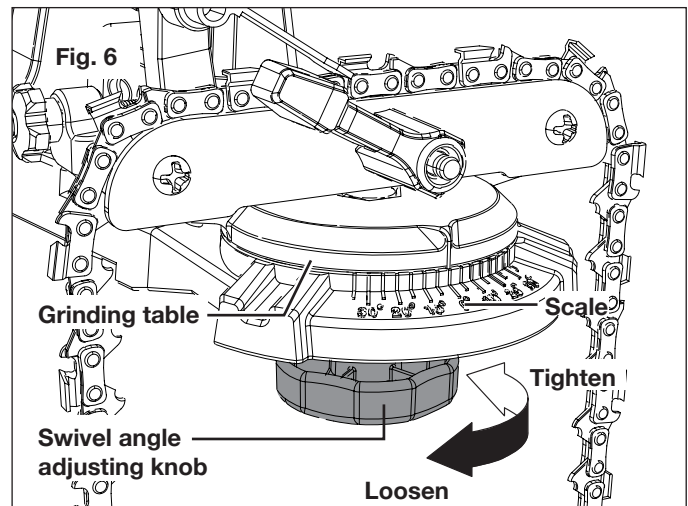

- Loosen the swivel angle adjusting knob for setting the swivel angle (Fig. 6).
- Set the desired grinding angle by rotating the grinding table by hand. Use the scale below the grinding table to get the desired angle (Fig. 6).
- Tighten the swivel angle adjusting knob. Make sure the grinding table is locked securely (Fig. 6).

Adjust the Chain Stop

If the grinding wheel is not touching the chain tooth that needs to be sharpened when the motor head assembly is folded down, move the chain stop as indicated below.

1. Loosen the chain stop locking knob so the chain stop adjusting knob can be screwed by hand (Fig. 7). Rotate the chain stop adjusting knob to move the chain stop (Fig. 8).

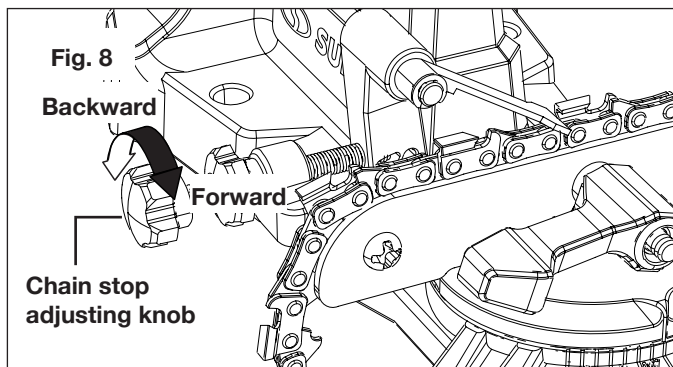
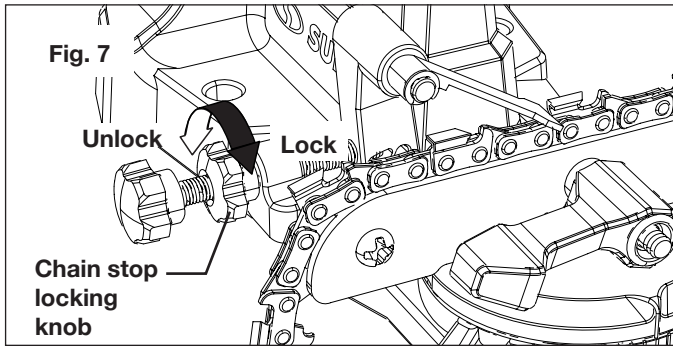

2. During adjusting, fold down the motor head assembly to see if the grinding wheel touches the tooth (Fig. 9).

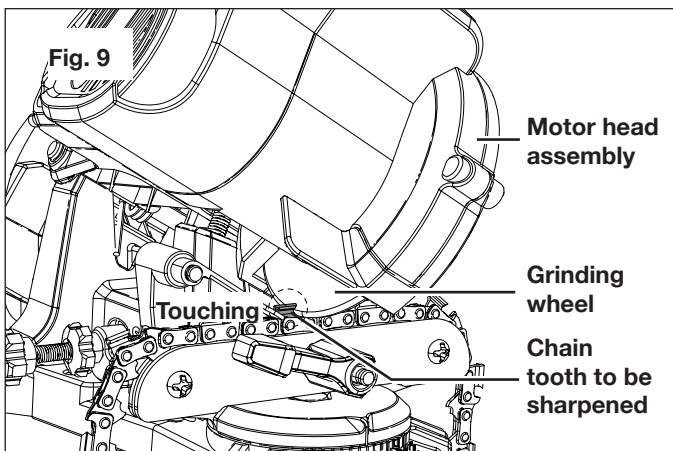

3. When the chain stop is in the correct position, lock the chain stop locking knob and make sure the chain stop will not move anymore (Fig. 7).

4. Flip the chain guide lock to the lock position. Make sure the chain is hold securely (Fig. 10).

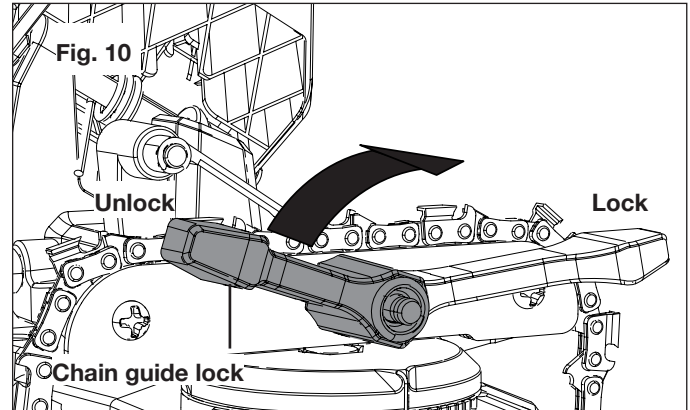

Adjust the Grinding Depth

The grinding depth must be adjusted properly so that the grinding wheel will not cut too deep between the teeth, which will cause the metal between the teeth being cut and damage to the chain.

1. Fold down the motor head assembly and check if the grinding wheel properly touches the inside curve of the tooth to be sharpened. If not, loosen the grinding depth locking knob on the back to adjust the grinding depth (Fig. 11).

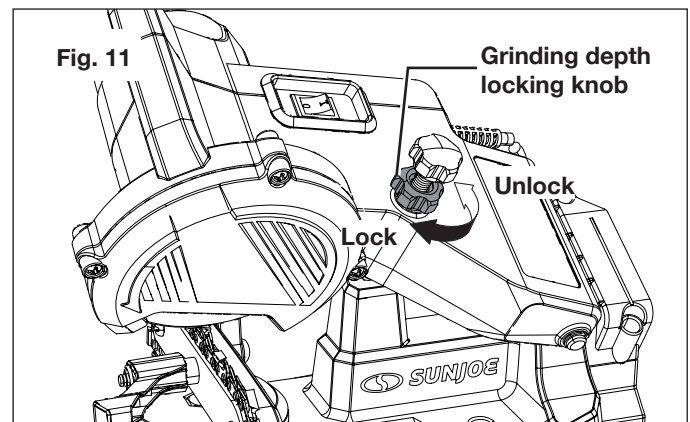

2. Adjust the grinding depth by turning the grinding depth adjusting knob (Fig. 12). The grinding wheel should just touch the inside edge of the tooth, not the bottom of the tooth (Fig. 13).

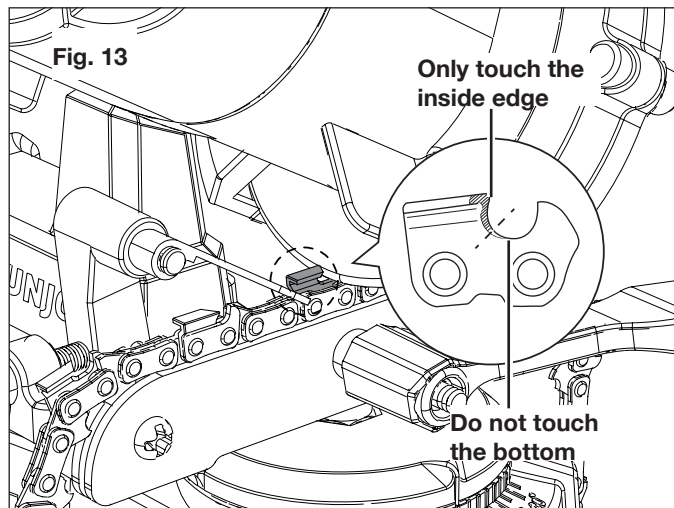
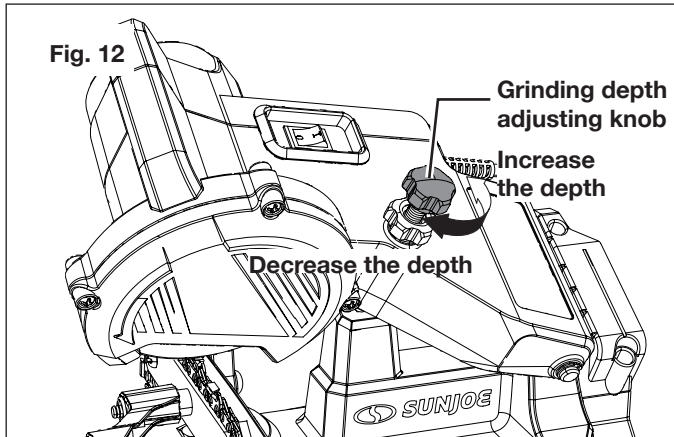

3. When reaching the proper grinding depth, lock the grinding depth locking knob by rotate it clockwise (Fig. 11).

Basic Sharpening Procedure

1. Put on your protective gear and make sure the immediate area is clear of bystanders.
2. Insert the battery into the battery compartment on the back of the machine, until it clicks into position. Press the On/Off switch on the ON (I) side to turn on the machine (Fig. 14).

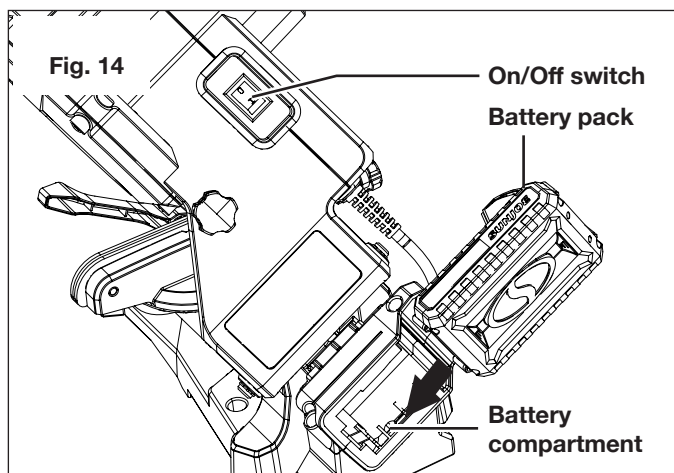

3. Hold the upper handle and slowly lower the motor head assembly (Fig. 15). If the setting is still off, turn off the unit and remove the battery before making adjustments.

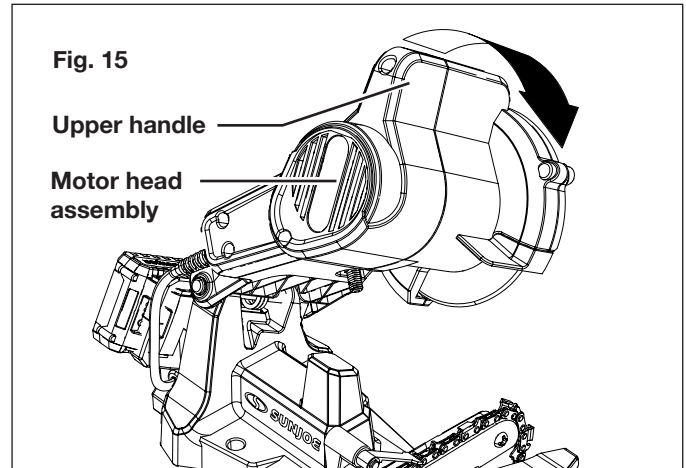

4. It's normal that during the operation there will be a slight amount of sparks. Lift the motor head assembly often and examine the tooth. If there's a full curve of the tooth with a shiny metal finish, the tooth is well sharpened.

Note: A good grind occurs when the contact between the wheel and the teeth are gradual and smooth. Do not keep the grinding wheel in contact with one tooth for too long.

5. After sharpening one tooth, turn off the machine by pressing the OFF(O) side of the On/Off switch. Lift up the motor head assembly. Flip the chain guide lock to the unlock position and move the chain so that the next chain tooth comes before the chain stop. Flip the chain guide lock to the lock position and continue to sharpen the next tooth. Repeat this process until you have sharpened all the teeth on the same side (Fig. 16).

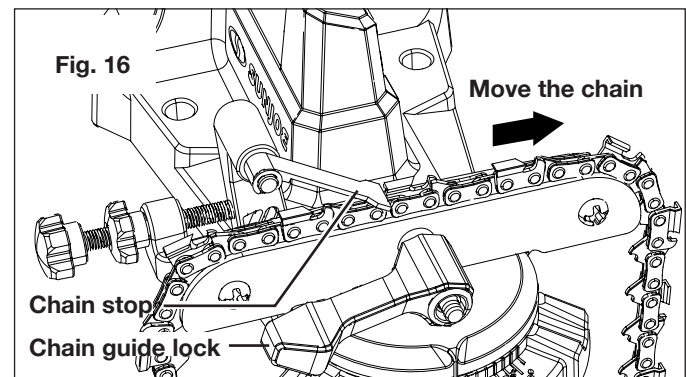

6. After you finished sharpening all of the teeth on one side, turn off the machine and remove the battery. Loosen the swivel angle adjusting knob and reset the swivel angle to the same angle on the other side (e.g. if you use 20° on right as the swivel angle for one side, set it to 20° on left for the other side) (Fig. 17).

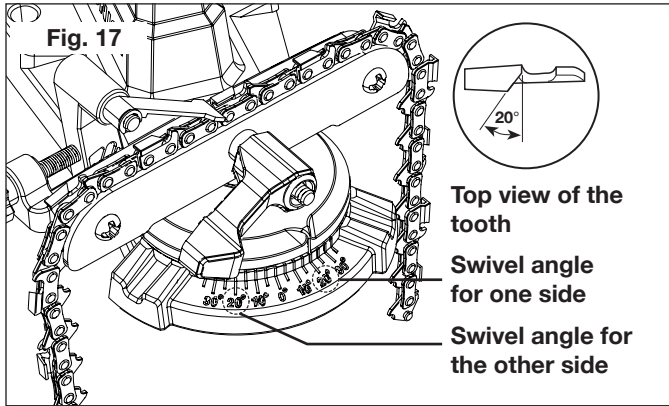

Note: Refer to Set the Swivel Angle section on page 10 for detailed instruction of how to adjust the swivel angle.

7. The other side of the chain teeth should be able to fit the same setting of chain stop and grinding depth. However, it's recommended to double check everything before inserting the battery and turning on the machine.
8. After all of the teeth have been sharpened, turn off the machine and remove the battery.

Operating Tips

⚠ WARNING! To ensure that the chain saw works safely and efficiently, it is essential that the cutting components are well-sharpened. Any work on the chain and bar requires specific experience and special tools.

Sharpening is necessary when:

- the sawdust looks like dust;
- cutting becomes more difficult;
- the cut is not straight;
- vibrations increase.

After sharpening, check that the depth limiter tooth does not stick out farther than the inspection tool and file any projecting parts with a flat file (not included), rounding off the edges (Fig. 18).

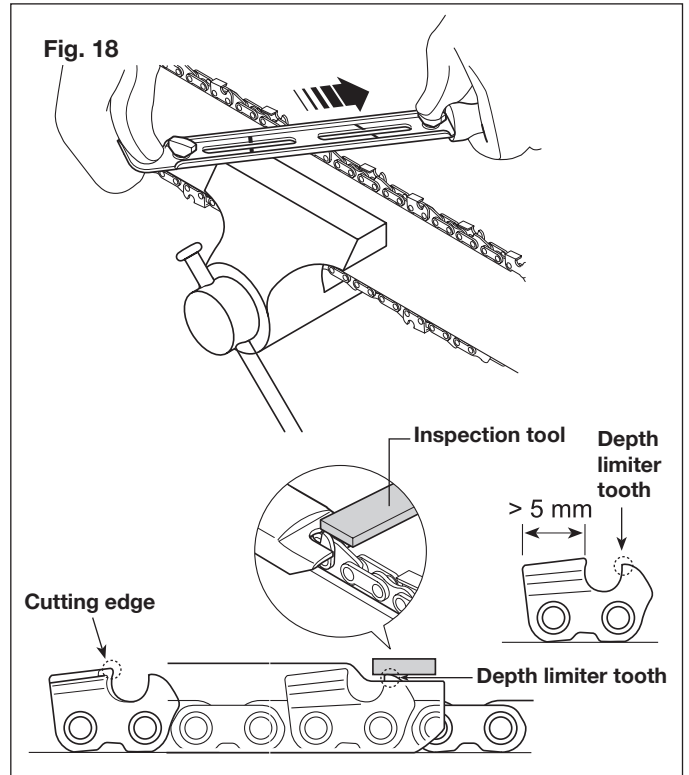

Maintenance

Please contact an authorized Snow Joe® + Sun Joe® dealer or call the Snow Joe® + Sun Joe® customer service center at 1-866-SNOWJOE (1-866-766-9563) for all maintenance operations not foreseen in this manual. Any operation performed in an unauthorized service center or by unqualified personnel will completely invalidate the warranty.

Maintain the product with the following recommended procedures. It is recommended to check the general condition of every part before using. Keep your tool in good condition. Keep all cutting edges sharp and clean. Properly maintained cutting tools with sharp cutting edges are less likely to bind and are easier to control. Keep handles dry, clean, and free from oil and grease.

Cleaning

We recommend that you clean the device everytime immediately after using. Clean with a moist cloth and a soft soap or blow it with compressed air at low pressure.

- Remove the battery each time before cleaning.
- Keep all safety devices, air vents and the motor housing free of dirt and dust as far as possible.
- Do not use cleaning agents or solvents; these could attack the plastic parts of the equipment. Ensure that no water can seep into the device.

Replacing the Grinding Wheel

Check the grinding wheel before each use to make sure it's not damaged. Do not use a grinding wheel if it is chipped, cracked, or worn. You can check if the wheel has minor cracks by hanging it up by the central hole and tapping it with a non metal object (ie; screwdriver handle). A grinding wheel in good condition will produce a metallic sound. A dull sound indicates a crack or break.

Replace the grinding wheel when it grinds down to a outside diameter of 3 inches.

⚠️ WARNING! This cordless chain saw sharpener uses a standard 4.25 inch x 1/8 inch grinding wheel with 100 grit. Only use the identical grinding wheels for replacement. Grinding wheels of other sizes may cause malfunction or personal injury.

⚠️ CAUTION! Wear heavy duty gloves when handling with the grinding wheel.

1. Before handling the grinding wheel, turn off the machine and remove the battery. Wait until the grinding wheel comes to a complete stop.
2. Remove the 3 screws used for securing the grinding wheel guard, then remove the grinding wheel guard and expose the worn grinding wheel (Fig. 19).

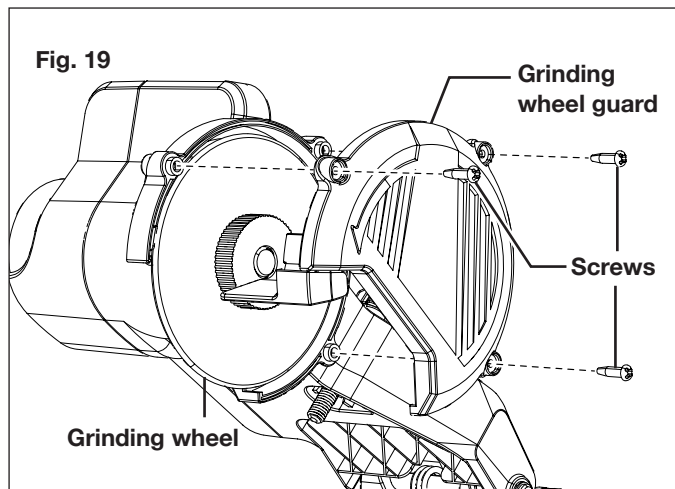

3. To remove the worn grinding wheel, rotate the grinding wheel retainer counterclockwise (Fig. 20) to unlock, then take out the retainer and the worn wheel.

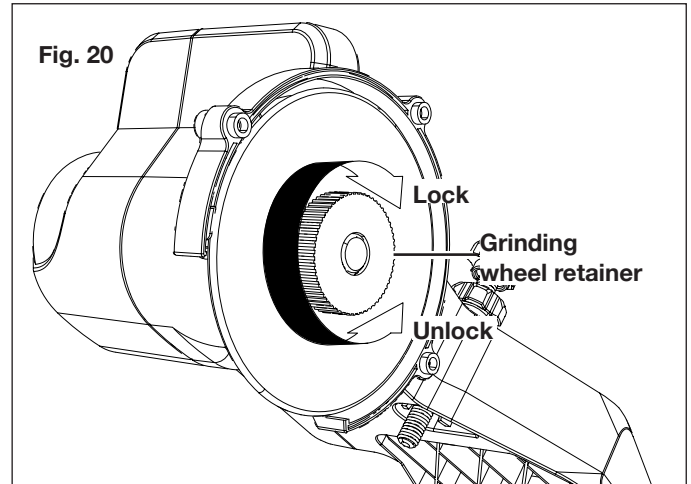

4. Place the new grinding wheel in position, fix it by the grinding wheel retainer.

NOTE: Examine the grinding wheel and adjust the tightness of the retainer to make sure the grinding wheel can rotate freely. DO NOT overtighten the grinding wheel retainer.

5. Replace the grinding wheel guard, fix with the original screws.

⚠️ CAUTION! Never operate a chain saw sharpener without a proper installed grinding wheel guard.

NOTE: It's recommended to perform a test run for at least 30 seconds with no load before using this product for the first time and after changing the grinding wheel. Switch off the product immediately if the grinding wheel is no longer round or irregular, considerable vibration occurs or you notice abnormal noise.

Proper Care for Battery + Charger

⚠️ WARNING! To reduce the risk of injury, always unplug the charger and remove the battery pack from the charger before performing any maintenance task. Never disassemble the battery pack or charger. Contact your Snow Joe® + Sun Joe® dealer or the Snow Joe® + Sun Joe® customer service center for ALL repairs.

1. To reduce the risk of injury and damage, never immerse your battery pack or charger in liquid or allow any liquid to flow inside these components.
2. Clean out dust and debris from charger vents and electrical contacts by blowing with compressed air.
3. Use only mild soap on a damp cloth to clean the battery pack and charger, keeping away from all electrical contacts. Certain cleaning agents and solvents are harmful to plastics and other insulated parts. Some of these include gasoline, turpentine, lacquer thinner, paint thinner, chlorinated cleaning solvents, ammonia and household detergents containing ammonia. Never use flammable or combustible solvents around battery packs, battery chargers or tools.

4. The iON+ 24VCHRG-AC lithium-ion battery charger has no serviceable parts.

Storage

1. Examine the cordless chain saw sharpener thoroughly for worn, loose or damaged parts. Should you need to repair or replace a part, contact an authorized Snow Joe® + Sun Joe® dealer or call the Snow Joe® + Sun Joe® customer service center at 1-866-SNOWJOE (1-866-766-9563) for assistance.
2. Remove the battery from the cordless chain saw sharpener before storing.
3. Store the cordless chain saw sharpener indoors in a locked, dry place out of the reach of children to prevent unauthorized use or damage.

Battery + Charger Off-Season Storage

1. Do not expose your battery pack or charger to water, rain or allow them to get wet. This could permanently damage the charger and the battery pack. Do not use oil or solvents to clean or lubricate your battery pack as the plastic casing can become brittle and crack, causing a serious risk of injury.
2. Store the battery pack and charger at room temperature away from moisture. Do not store in damp locations where corrosion of terminals may occur. As with other battery pack types, permanent capacity loss can result if the pack is stored for long periods of time at high temperatures (over 120°F/49°C).
3. iON+ 24VBAT-LTE lithium-ion battery packs maintain their charge during storage longer than other battery pack types. As a general practice, it is best to unplug the battery charger and remove the battery pack when they are not in use. Recharge the battery pack every 6 months to 50% capacity (2 lights on) during off-season storage to maintain optimal battery performance.

Battery Caution + Disposal

Always dispose of your battery pack according to federal, state, and local regulations. Contact a recycling agency in your area for recycling locations.

⚠ CAUTION! Even discharged battery packs contain some energy. Before disposing, use electrical tape to cover the terminals to prevent the battery pack from shorting, which could cause a fire or explosion.

⚠ WARNING! To reduce the risk of injury or explosion, never burn or incinerate a battery pack even if it is damaged, dead or completely discharged. When burned, toxic fumes and materials are emitted into the surrounding atmosphere.

1. Batteries vary according to device. Consult your manual for specific information.
2. Install only new batteries of the same type in your product (where applicable).

3. Failure to insert batteries in the correct polarity, as indicated in the battery compartment or manual, may shorten the life of the batteries or cause batteries to leak.
4. Do not mix old and new batteries.
5. Do not mix Alkaline, Standard (Carbon-Zinc) or Rechargeable (Nickel Cadmium, Nickel Metal Hydride, or Lithium-Ion) batteries.
6. Do not dispose of batteries in fire.
7. Batteries should be recycled or disposed of as per state and local guidelines.

Service and Support

If your Sun Joe® 24V-CSSHRP-LTE cordless chain saw sharpener requires service or maintenance, please call the Snow Joe® + Sun Joe® customer service center at 1-866-SNOWJOE (1-866-766-9563).

Model and Serial Numbers

When contacting the company, reordering parts or arranging service from an authorized dealer, you will need to provide the model and serial numbers, which can be found on the decal located on the housing of the unit. Copy these numbers into the space provided below.

Record the following numbers from the housing or handle of your new product:	
Model #:	_____
Serial #:	_____

24VCHRG-AC

Federal Communications Commission (FCC)

⚠ WARNING! Any changes or modifications to this unit not expressly approved by the party responsible for compliance could void the user's authority to operate the equipment.

Class B device:

NOTE: This equipment has been tested and found to comply with the limits for a Class B digital device, pursuant to part 15 of the FCC Rules.

These limits are designed to provide reasonable protection against harmful interference in a residential installation.

This equipment generates, uses and can radiate radio frequency energy and, if not installed and used in accordance with the instructions, may cause harmful interference to radio communications.



However, there is no guarantee that interference will not occur in a particular installation.

If this equipment does cause harmful interference to radio or television reception, which can be determined by turning the equipment off and on, the user is encouraged to try to correct the interference by one or more of the following measures:

- Reorient or relocate the receiving antenna.
- Increase the separation between the equipment and receiver.
- Connect the equipment into an outlet on a circuit different from that to which the receiver is connected.
- Consult the dealer or an experienced radio/TV technician for help.

Optional Accessories

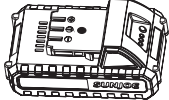
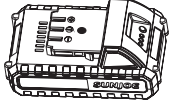
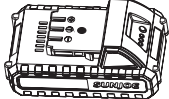
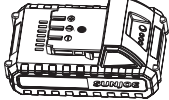
⚠️ WARNING! ALWAYS use only authorized Snow Joe® + Sun Joe® replacement parts and accessories. NEVER use replacement parts or accessories that are not intended for use with this cordless chain saw sharpener. Contact Snow Joe® + Sun Joe® if you are unsure whether it is safe to use a particular replacement part or accessory with your cordless chain saw sharpener. The use of any other attachment or accessory can be dangerous and could cause injury or mechanical damage.

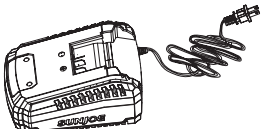
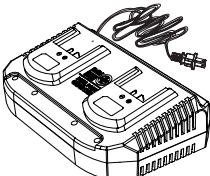
Accessories	Item	Model
	24V iON+ 1.3 Ah Lithium-Ion Battery <i>Battery Charge Time Max:</i> 24VCHRG-AC: 50 min 24VCHRG-QC: 35 min 24VCHRG-DPC: 35 min <i>Battery Runtime Max: 25 min</i>	24VBAT-LTW
	24V iON+ 1.5 Ah Lithium-Ion Battery <i>Battery Charge Time Max:</i> 24VCHRG-AC: 60 min 24VCHRG-QC: 40 min 24VCHRG-DPC: 40 min <i>Battery Runtime Max: 30 min</i>	24VBAT-LTX
	24V iON+ 2.0 Ah Lithium-Ion Battery <i>Battery Charge Time Max:</i> 24VCHRG-AC: 1 hr 20 min 24VCHRG-QC: 55 min 24VCHRG-DPC: 55 min <i>Battery Runtime Max: 40 min</i>	24VBAT-LTE
	24V iON+ 2.5 Ah Lithium-Ion Battery <i>Battery Charge Time Max:</i> 24VCHRG-AC: 1 hr 40 min 24VCHRG-QC: 1 hr 20 min 24VCHRG-DPC: 1 hr 10 min <i>Battery Runtime Max: 50 min</i>	24VBAT-LT
	24V iON+ 4.0 Ah Lithium-Ion Battery <i>Battery Charge Time Max:</i> 24VCHRG-AC: 3 hrs 30 min 24VCHRG-QC: 1 hr 50 min 24VCHRG-DPC: 1 hr 50 min <i>Battery Runtime Max: 80 min</i>	24VBAT
	24V iON+ 5.0 Ah Lithium-Ion Battery <i>Battery Charge Time Max:</i> 24VCHRG-AC: 3 hrs 20 min 24VCHRG-QC: 2 hr 20 min 24VCHRG-DPC: 2 hr 30 min <i>Battery Runtime Max: 100 min</i>	24VBA-XR
	24V iON+ Lithium-Ion Battery Quick Charger	24VCHRG-QC
	24V iON+ Lithium-Ion Dual-port Battery Charger	24VCHRG-DPC

NOTE: Accessories are subject to change without any obligation on the part of Snow Joe® + Sun Joe®. Accessories can be ordered online at sunjoe.com or via phone by contacting the Snow Joe® + Sun Joe® customer service center at 1-866-SNOWJOE (1-866-766-9563).



SNOW JOE® + SUN JOE® CUSTOMER PROMISE

ABOVE ALL ELSE, Snow Joe® + Sun Joe® are dedicated to you, our customer. We strive to make your experience as pleasant as possible. Unfortunately, there are times when a product does not work or breaks under normal operating conditions. We think it's important that you know what you can expect from us. That's why we created the Snow Joe® + Sun Joe® promise.

OUR PROMISE: Snow Joe® + Sun Joe® warrant new products for two years from the date of purchase. If your product does not work, or there's an issue with a specific part, we will fix this by either sending you a free replacement part or by sending you a new or comparable product at no charge. How cool is that! Before you know it, you'll be back in action cutting, sawing, mowing, washing and...?

PRODUCT REGISTRATION:

Snow Joe®, LLC ("Snow Joe® + Sun Joe®") strongly encourages you to register your purchase. You can register online at snowjoe.com/ProductRegistration, or by printing and mailing in a registration card available online from our website, or calling our Customer Service Department at **1-866-SNOWJOE (1-866-766-9563)**, or by e-mailing us at help@snowjoe.com. Failure to register your product purchase will not diminish your warranty rights. However, registering your purchase will allow Snow Joe® + Sun Joe® to better serve you with any of your customer service needs.

WHO CAN SEEK WARRANTY COVERAGE?

This Warranty is extended by Snow Joe® + Sun Joe® to the owner of this Machine (a "Machine" consists of a product powered by a motor) for residential and personal household use only. This Warranty does not apply to products used for commercial, rental or re-sale purposes. Should ownership of this machine change during the 2-year period, please update the Machine's owner information at snowjoe.com/ProductRegistration.

WHAT IS COVERED?

Snow Joe® + Sun Joe® warrants to the owner that if this Machine fails within 2 years from the date of purchase due to a defect in material or workmanship or as a result of normal wear and tear from ordinary household use, Snow Joe® + Sun Joe® will send a replacement part or product, as needed, free of charge and with free shipping to the original purchaser.

If, in Snow Joe® + Sun Joe®'s sole discretion, the failed Machine cannot be repaired with a part, Snow Joe® + Sun Joe® will elect to either (A) send a new Machine at no charge and with free shipping or (B) refund the full purchase price to the owner.

WHAT IS NOT COVERED?

This Warranty does not apply to the Machines that have been used commercially or in non-household applications. This Warranty does not cover cosmetic changes that do not affect performance. This Warranty is only valid if the Machine is used and maintained in accordance with the instructions, warnings and safeguards contained in the owner's manual. Snow Joe® + Sun Joe® will not be responsible for the cost of any unauthorized warranty repairs. This warranty does not cover any cost or expense incurred by the purchaser in providing substitute equipment or service during reasonable periods of malfunction or non-use of this product while waiting for a replacement part or unit under this warranty.

Wearing parts like belts, augers, chains and tines are not covered under this warranty, and can be purchased at snowjoe.com or by calling **1-866-SNOWJOE (1-866-766-9563)**. Batteries are covered in full for 90-days from the date of purchase.

Repair, replacement or refund of the purchase price are the exclusive remedies of purchaser and the sole liability of Snow Joe® + Sun Joe® under this warranty. No employee or representative of Snow Joe® + Sun Joe® is authorized to make any additional warranty or any modification to this warranty which may be binding upon Snow Joe® + Sun Joe®. Accordingly, purchaser should not rely upon any additional statements made by any employee or representative of Snow Joe® + Sun Joe®. In no event, whether based on contract, indemnity, warranty, tort (including negligence), strict liability or otherwise, shall Snow Joe® + Sun Joe® be liable for any special, indirect, incidental, or consequential damages, including, without limitation, loss of profit or revenue.

Some states do not allow limits on warranties. In such states, the above limitations may not apply to you.

Outside the USA, other warranties may apply.



sunjoe.com